

Technical Data

4000 Series

4012TEG

4012TEG2

Diesel Engine - Electrounit

Basic technical data

Number of cylinders ... 12
 Cylinder arrangement ... 60°
 Cycle ... 4 stroke, compression ignition
 Induction system ... Turbocharged
 Compression ratio ... 13.6:1 nominal
 Bore ... 160 mm
 Stroke ... 190 mm
 Cubic capacity ... 45.842 litres
 Direction of rotation ... Anti-clockwise viewed on flywheel
 Firing order ... 1^A,6^B,5^A,2^B,3^A,4^B,6^A,1^B,2^A,5^B,4^A,3^B
 Cylinders 1 furthest from flywheel
 Total weight Electrounit (engine only) ... (dry) 4440 kg
 ... (wet) 4604 kg
 Overall dimensions ... Height 2118 mm
 ... Length 2731 mm
 ... Width 1547 mm
 Moment of inertia ... 4012TEG Engine 7.26 Flywheel 9.57 kgm²
 ... 4012TEG2 Engine 9.72 Flywheel 9.57 kgm²
 Cyclic irregularity for engine/flywheel (Prime power):
 1500. rev/min... 1.649... 4012TEG
 1500. rev/min... 1.656.. 4012TEG2

Ratings

Steady state speed stability at constant load ... ± 0.25%
 Electrical ratings are based on average alternator efficiency and are for guidance only (0.8 power factor being used).

Operating point

Engine speed ... 1500 rev/min
 Static injection timing... See engine number plate
 Cooling water exit temp... <93 °C

Fuel data

To conform to BS2869 class A1, A2.

Performance

Sound pressure level 1500 rev/min ... 105/108 d(B)A

Note: All data based on operation to ISO 3046/1, BS 5514 and DIN 6271 standard reference conditions.

Test Conditions

Air temperature... 25 °C
 Barometric pressure... 100 kPa
 Relative humidity ... 30%
 Air inlet Restriction at maximum power (nominal) .. 2.5 kPa
 Exhaust back pressure (nominal)... 3.0 kPa
 For load acceptance figures please refer to Applications Dept.

General installation 4012TEG

Designation	Units	50Hz 1500 rev/min			60Hz 1800 rev/min		
		Continuous Baseload	Prime Power	Standby Maximum	Continuous Baseload	Prime Power	Standby Maximum
Gross engine power	kWb	860	1075	1182	-	-	-
Fan power	kWm	N/A			-		
Net engine power	kWm	As gross	As gross	As gross	-	-	-
BMEP gross	bar	15.0	18.8	20.6	-	-	-
Combustion air flow	m ³ /min	81	99	97	-	-	-
Exhaust gas temperature max (after turbo)	°C	451			-		
Exhaust gas flow max (after turbo)	m ³ /min	243			-		
Boost pressure ratio	-	2.60	2.80	3.05	-	-	-
Mechanical efficiency	%	88	90	91	-	-	-
Overall thermal efficiency	%	42	41	41	-	-	-
Friction power and pumping losses	kWm		120		-		
Mean piston speed	m/s	9.5			-		
Engine coolant flow	l/s	16.4			-		
Typical Genset Electrical Output 0.8pf 25 °C (100kPa)	kVA	1032	1290	1418	-	-	-
	kWe	826	1032	1135	-	-	-
Assumed alternator efficiency	%	96			-		

General installation 4012TEG2

Designation	Units	50Hz 1500 rev/min			60Hz 1800 rev/min		
		Continuous Baseload	Prime Power	Standby Maximum	Continuous Baseload	Prime Power	Standby Maximum
Gross engine power	kWb	1035	1294	1423	-	-	-
Fan power	kWm	N/A			-		
Net engine power	kWm	As gross	As gross	As gross	-	-	-
BMEP gross	bar	18.1	22.6	24.8	-	-	-
Combustion air flow	m ³ /min	89	106	110	-	-	-
Exhaust gas temperature max (after turbo)	°C	487			-		
Exhaust gas flow max (after turbo)	m ³ /min	291			-		
Boost pressure ratio	-	2.80	3.40	3.65	-	-	-
Mechanical efficiency	%	90	87	92	-	-	-
Overall thermal efficiency	%	42	41	40	-	-	-
Friction power and pumping losses	kWm	120			-		
Mean piston speed	m/s	9.5			-		
Engine coolant flow	l/s	16.4			-		
Typical Genset Electrical Output 0.8pf 25 °C (100kPa)	kVA	1242	1553	1708	-	-	-
	kWe	994	1242	1366	-	-	-
Assumed alternator efficiency	%	96			-		

Note: Not to be used for CHP design purposes. (Indicative figures only). Consult Perkins Engines Co. Ltd. Assumes complete combustion.

Continuous Baseload rating Power available for continuous full load operation. **Prime Power rating** is available for unlimited hours per year with a variable load of which the average engine load factor is 80% of the published prime power rating, incorporation of a 10% overload for 1 hour in every 12 hours of operation which is permitted. **Standby Power rating** is for the supply of emergency power at variable load for the duration of the non-availability of the mains power supply. NO OVERLOAD capacity is available at this rating. Engines must not be allowed to have facilities for parallel operation with the mains supply. This rating should be applied only when reliable mains power is available. Should this not be the case then refer to Prime Power rating. A standby rated engine should be sized for an average load factor of 80% based on published standby rating for 500 operating hours per year. Standby ratings should never be applied except in true emergency power failure conditions.

Energy balance

Note: Not to be used for CHP design purposes. (indicative figures only). Consult Perkins Engines Co. Assumes complete combustion.

4012TEG

	Units	1500 rev/min			1800 rev/min		
		Continuous Baseload	Prime Power	Standby Maximum	Continuous Baseload	Prime Power	Standby Maximum
Energy in fuel	kWt	2053	2617	2906	-	-	-
Energy in power output (Gross)	kWb	860	1075	1182	-	-	-
Energy to cooling fan	kWm	N/A	N/A	N/A	-	-	-
Energy in power output (Net)	kWm	As gross	As gross	As gross	-	-	-
Energy to exhaust	kWt	693	861	941	-	-	-
Energy to coolant and oil	kWt	311	406	451	-	-	-
Energy to radiation	kWt	75	91	102	-	-	-
Energy to charge coolers	kWt	114	184	230	-	-	-

4012TEG2

	Units	1500 rev/min			1800 rev/min		
		Continuous Baseload	Prime Power	Standby Maximum	Continuous Baseload	Prime Power	Standby Maximum
Energy in fuel	kWt	2470	3180	3539	-	-	-
Energy in power output (Gross)	kWb	1035	1294	1423	-	-	-
Energy to cooling fan	kWm	N/A	N/A	N/A	-	-	-
Energy in power output (Net)	kWm	As gross	As gross	As gross	-	-	-
Energy to exhaust	kWt	795	1014	1157	-	-	-
Energy to coolant and oil	kWt	378	468	514	-	-	-
Energy to radiation	kWt	86	108	120	-	-	-
Energy to charge coolers	kWt	176	296	325	-	-	-

Cooling system

Recommended coolant: 50% inhibited ethylene glycol or 50% inhibited propylene glycol and 50% clean fresh water. For combined heat and power systems and where there is no likelihood of ambient temperature below 10 °C then clean 'soft' water may be used, treated with 1% by volume of Perkins inhibitor in the cooling system. The inhibitor is available in bottles under Perkins Part No. OE 45350 (1 litre).

Nominal jacket water pressure in crankcase 1.7 bar

The following is a guide based on ambient air conditions of 52 °C on a Perkins supplied radiator

Total coolant capacity:

Electrounit (engine only) 73 litres

Electropak (engine/radiator) N/A litres

Pressure cap setting N/A bar

Fan N/A

Diameter N/A

Heat exchanger: Optional (in lieu of radiator)

Charge cooler: fin and tube (on engine separate to radiator)

Ambient Cooling Clearance (Open Electropak Prime power) based on air temp at fan 3 °C above ambient.

4012TEG

Maximum additional restriction (duct allowance) to cooling airflow (Prime power) and resultant minimum airflow					
Ambient Clearance 50% glycol		Duct Allowance mm H ₂ O		Min airflow m ³ /min	
rev/min		rev/min		rev/min	
1500	1800	1500	1800	1500	1800
52 °C	52 °C	-	-	-	-

4012TEG2

Maximum additional restriction (duct allowance) to cooling airflow (Prime power) and resultant minimum airflow					
Ambient Clearance 50% glycol		Duct Allowance mm H ₂ O		Min airflow m ³ /min	
rev/min		rev/min		rev/min	
1500	1800	1500	1800	1500	1800
52 °C	52 °C	-	-	-	-

Coolant pump speed and method of drive 1.4 x e rev/min Gear

Maximum static pressure head on pump above engine crank centre line 7 m

Maximum external permissible restriction to coolant pump flow 20 KPa

Thermostat operating range 71-85 °C

Shutdown switch setting 96 °C rising

Coolant immersion heater capacity 4 kW x 2

Jacket cooling water data	Units	1500 rev/min	1800 rev/min
Coolant flow	l/s	16.4	-
Coolant exit temperature (max)	°C	93	-
Coolant entry temperature (min)	°C	70	-
Coolant entry temperature (max)*	°C	88	-
Coolant entry temperature (max)**	°C	85	-

* 4012TEG ** 4012TEG2

Charge cooling water data	Units	1500 rev/min	1800 rev/min
Coolant flow	l/s	10.0	-

Lubrication system

Recommended lubricating oil to conform with the specification of APICD or MIL - L - 2104C

Lubricating oil capacity:

Sump maximum 157,5 litres

Sump minimum 115 litres

Lubricating oil temperature maximum to bearings 105 °C

Lubricating oil pressure:

at 80 °C temperature to bearing gallery (minimum) 0.34 MPa

4012TEG

Oil consumption Prime Power	Units	1500 rev/min	1800 rev/min
After RUNNING - IN*	g/kWhr	0.51	-
Oil flow rate from pump	l/s	6.0	-

4012TEG2

Oil consumption Prime Power	Units	1500 rev/min	1800 rev/min
After RUNNING - IN*	g/kWhr	0.51	-
Oil flow rate from pump	l/s	6.0	-

*Typical after 250 hours

Sump drain plug tapping size G1

Oil pump speed and method of drive 1.4 x e rev/min, gear

Oil pump flow 1500 rev/min 6.0 litres/sec

Oil pump flow 1800 rev/min N/A litres/sec

Shutdown switch setting 1.93 bar falling

Normal operating angles

Fore and aft 5°

Side tilt 10°

Fuel system

Recommended fuel... To conform to BS2869 1998 Class A1,A2
 Type of injection system ... Direct injection
 Fuel injection pump... Combined Unit injector
 Fuel injector... Combined Unit Injector
 Fuel injector opening pressure... 234 bar
 Fuel lift pump... Tuthill TCH 1-089
 Delivery/hour at 1500 rev/min... 1020 litres
 Delivery/hour at 1800 rev/min... N/A litres
 Heat retained in fuel to tank... 8.5 kW
 Temperature of fuel at lift pump to be less than... 58 °C
 Fuel lift pump pressure... 3.0 bar
 Fuel lift pump maximum suction head... 2.5 m
 Fuel lift pump maximum pressure head (see installation manual)
 Fuel filter spacing... 10 microns
 Governor type... Electronic
 Torque at the Governor output shaft... 1.631 kgm
 Static injection timing... See engine number plate
 Tolerance on Fuel consumption... +5%

4012TEG

Fuel consumption gross				
Designation	g/kWh		Litres/hr	
	1500	1800	1500	1800
rev/min				
At Standby Max power rating	208	-	289	-
At Prime Power rating	206	-	261	-
At Continuous Baseload rating	202	-	204	-
At 75% of Prime Power rating	201	-	191	-
At 50% of Prime Power rating	208	-	132	-
At 25% of Prime power rating	237	-	75	-

4012TEG2

Fuel consumption gross				
Designation	g/kWh		Litres/hr	
	1500	1800	1500	1800
rev/min				
At Standby Max power rating	210	-	352	-
At Prime Power rating	208	-	317	-
At Continuous Baseload rating	202	-	246	-
At 75% of Prime Power rating	201	-	231	-
At 50% of Prime Power rating	202	-	154	-
At 25% of Prime power rating	240	-	91	-

Induction System

Emissions data with combustion air temperature of 25 °C
 at continuous base load

Maximum air intake restriction of engine:

Clean filter... 127 mm H₂O

Dirty filter... 377 mm H₂O

Air filter type... 4998.00.00 MF&T

Exhaust system

Maximum back pressure for total system

Designation	Units	1500 rev/min	1800 rev/min
4012TEG	mmH ₂ O	816	-
4012TEG2	mmH ₂ O	612	-

Exhaust outlet flange size... 2 x 254 mm (Table 'D')

Recommended pipe sizes Refer to Installation Manual.

Electrical system

Type... Insulated return
 Alternator... 24 volts with integral regulator
 Alternator output... 40 amps at a stabilised output 28 volts at
 20 °C ambient

Starter motor... 24 volts
 Starter motor power... 16.4 kW
 Number of teeth on flywheel... 156
 Number of teeth on starter motor... 12
 Minimum cranking speed (0 °C)... 120 rev/min
 Pull in current of each starter motor solenoid (2off)
 ... 30 amps at 24 volts
 Hold in current of each starter motor solenoid (2off)
 ... 9 amps at 24 volts
 Engine stop solenoid... 24 volts
 Pull in current of stop solenoid... 60 amps at 24 volts
 Hold in current of stop solenoid... 1.1 amps at 24 volts

Engine Mounting

Position of centre of gravity (wet engine) forward from rear
 face of crankcase... 658 mm
 Engine vertical centre line above crankshaft centre line... 38 mm
 Maximum additional load applied to flywheel due to all rotating
 components... 850 kg

Starting Requirements

Temperature Range	
Range Down to 0 °C (32 °F)	Oil: SAE 30 Starter: 2 x 24V Battery: 4 x 12 volts x Ah 286 Max breakaway current: 1600 amps Cranking current: 810 amps Aids: Not necessary Starter cable size: 120 mm Maximum length: 6m

Notes:

- Battery capacity is defined by the 20 hour rate at 0 °C.
- The oil specification should be for the minimum ambient temperature as the oil will not be warmed by the immersion heater.

Breakaway current is dependent on battery capacity available.
Cables should be capable of handling the transient current which may be up to double the steady cranking current

TYPICAL ENGINE

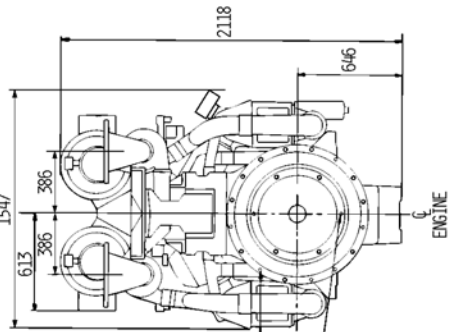
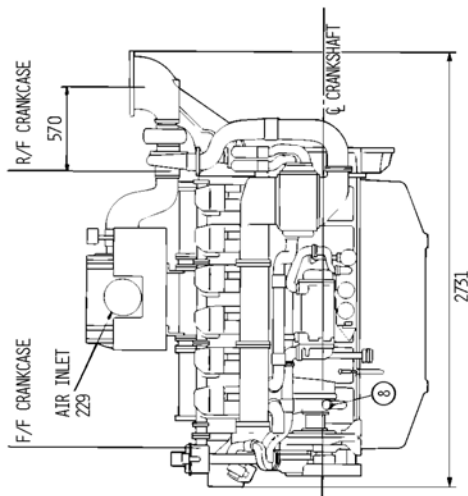

16 HOLES EQUALLY SPACED
1/2 UNC-2B ON
851 P.C.D.
6 HOLES EQUALLY SPACED
5/8 UNC-2B-30 DEEP ON
545 P.C.D.

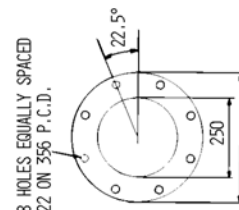
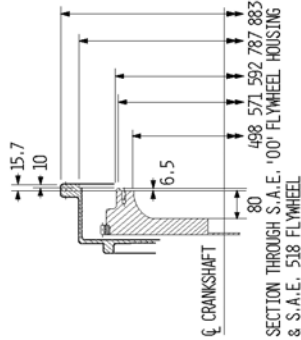

EXHAUST FLANGE 10" TABLE 'D'

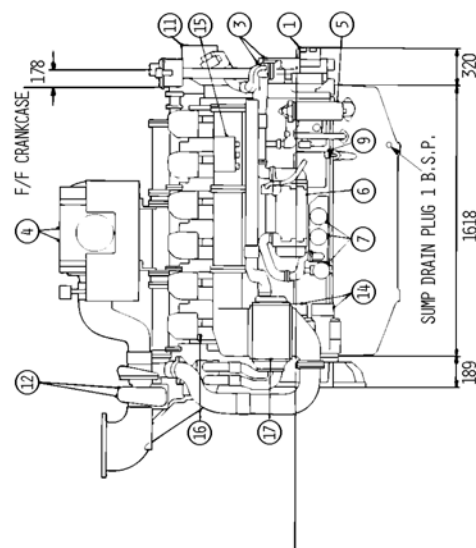

Electromit Support and Pad Dimensions

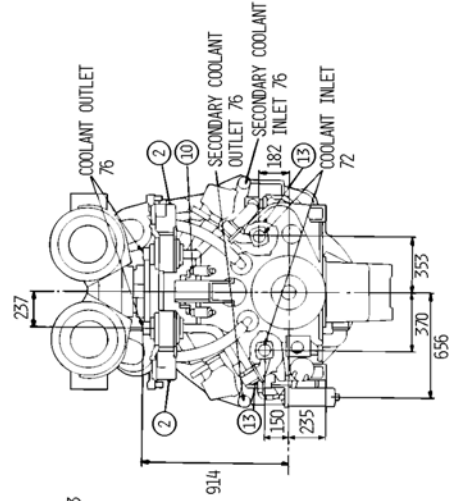
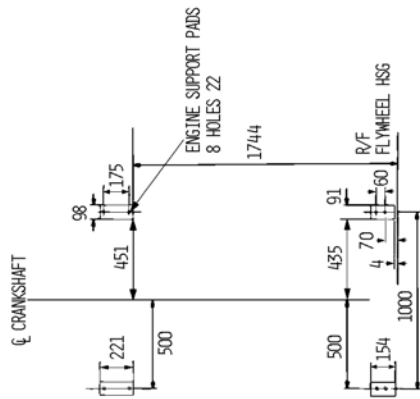

ITEM	DESCRIPTION
1	ALTERNATOR
2	BREATHERS
3	DAMPERS
4	AIR CLEANERS
5	FUEL FILTER & SEPARATOR
6	OIL COOLER
7	LUBRICATING OIL FILTERS
8	OIL FILLER
9	DIPSTICK
10	STOP SOLENOID
11	GOVERNOR ACTUATOR
12	TURBOCHARGERS
13	COOLANT PUMPS
14	24V STARTER
15	GOVERNOR CONTROL BOX
16	FUEL LEAK OFF
17	CHARGE COOLER

THIS DRAWING SHOWS APPROX DIMENSIONS ONLY. FOR INSTALLATION DETAILS, G.A. DRAWINGS MUST BE OBTAINED FROM PERKINS ENGINES COMPANY STAFFORD LTD. A 52°C AIR AMBIENT RADIATOR CAN BE SUPPLIED AS AN OPTION.

4012TEG & 4012TEG2 DIESEL ENGINES

Noise levels

The figures for total noise levels are typical for an engine running at Prime Power Rating in a semi-reverberant environment and measured at a distance of one metre from the periphery of the engine.

Octave analysis

The following histograms show an octave band analysis at the position of the maximum noise level.

Total noise level

Sound pressure level re: $- 20 \times 10^{-6}$ pa
 Speed 1500 r/min..... Ambient noise level - d(B)A.
 Octave analysis carried out at the position of maximum noise.

4012TEG

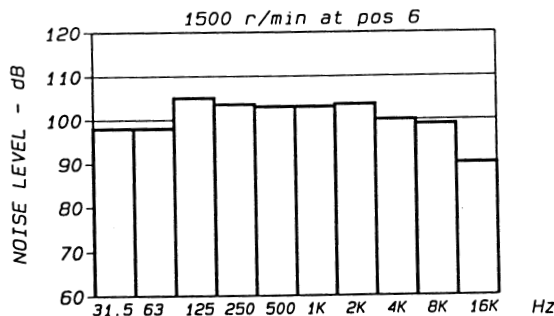
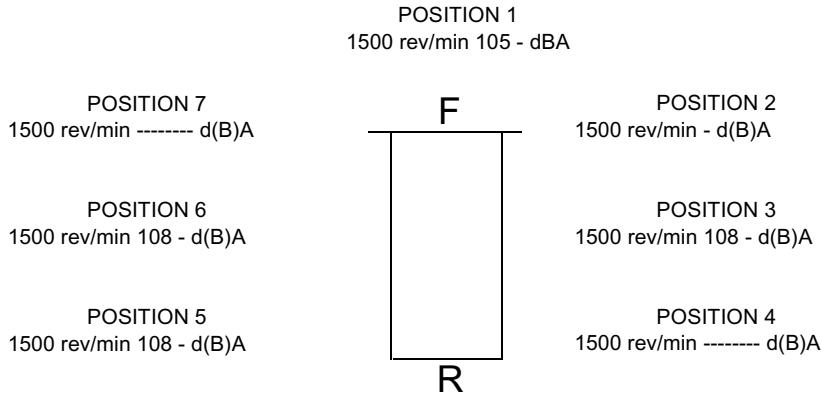

The information given on technical data sheets are for standard ratings only. For ratings other than shown contact Perkins Engines Co Ltd Stafford.

Notes

Perkins®
 Perkins Engines Company Limited
 Stafford ST16 3UB United Kingdom
 Telephone +44 (0)1785 223141
 Fax +44 (0)1785 215110
 www.perkins.com

Distributed by

All information in the document is substantially correct at the time of printing but may be subsequently altered by the company.